



Experience from More Than 10 Years of Work with Steamnet Control in Different Environments

Tomas Eriksson
Optimization AB



Steam Net Controls

- ▶ Pulp & paper
- ▶ Energy
- ▶ Mineral
- ▶ Total 18 installations

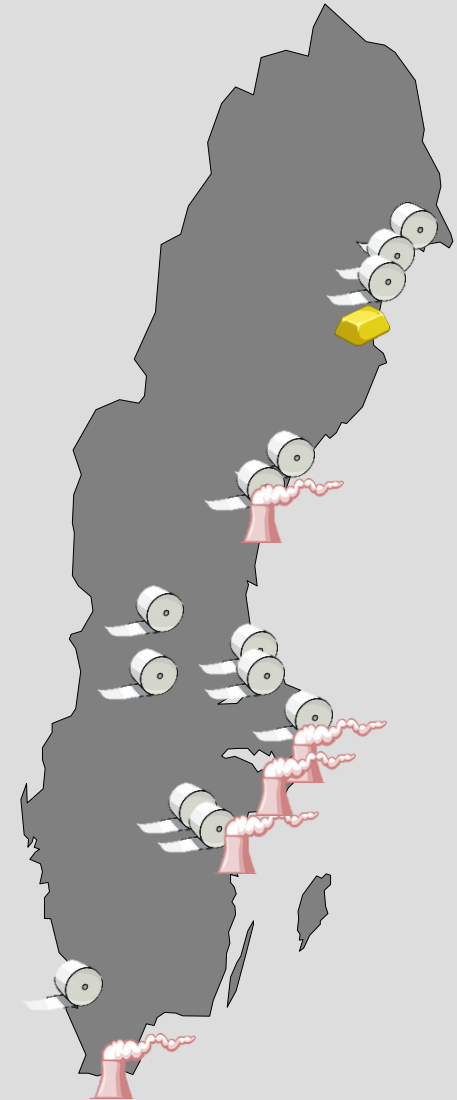



The Question:

What Makes an APC Installation Successful?



What is a Steam Net?

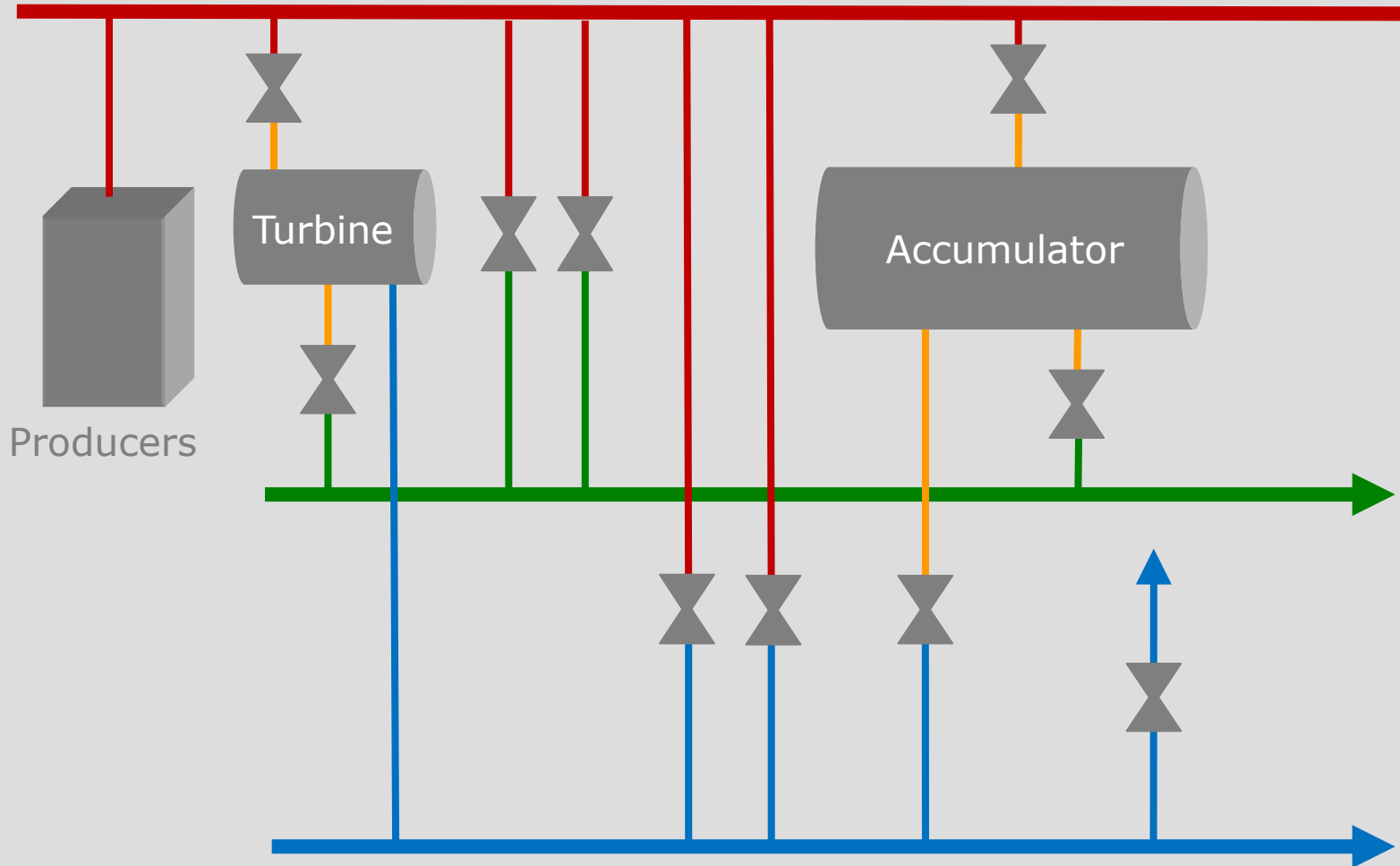



The Control Problem

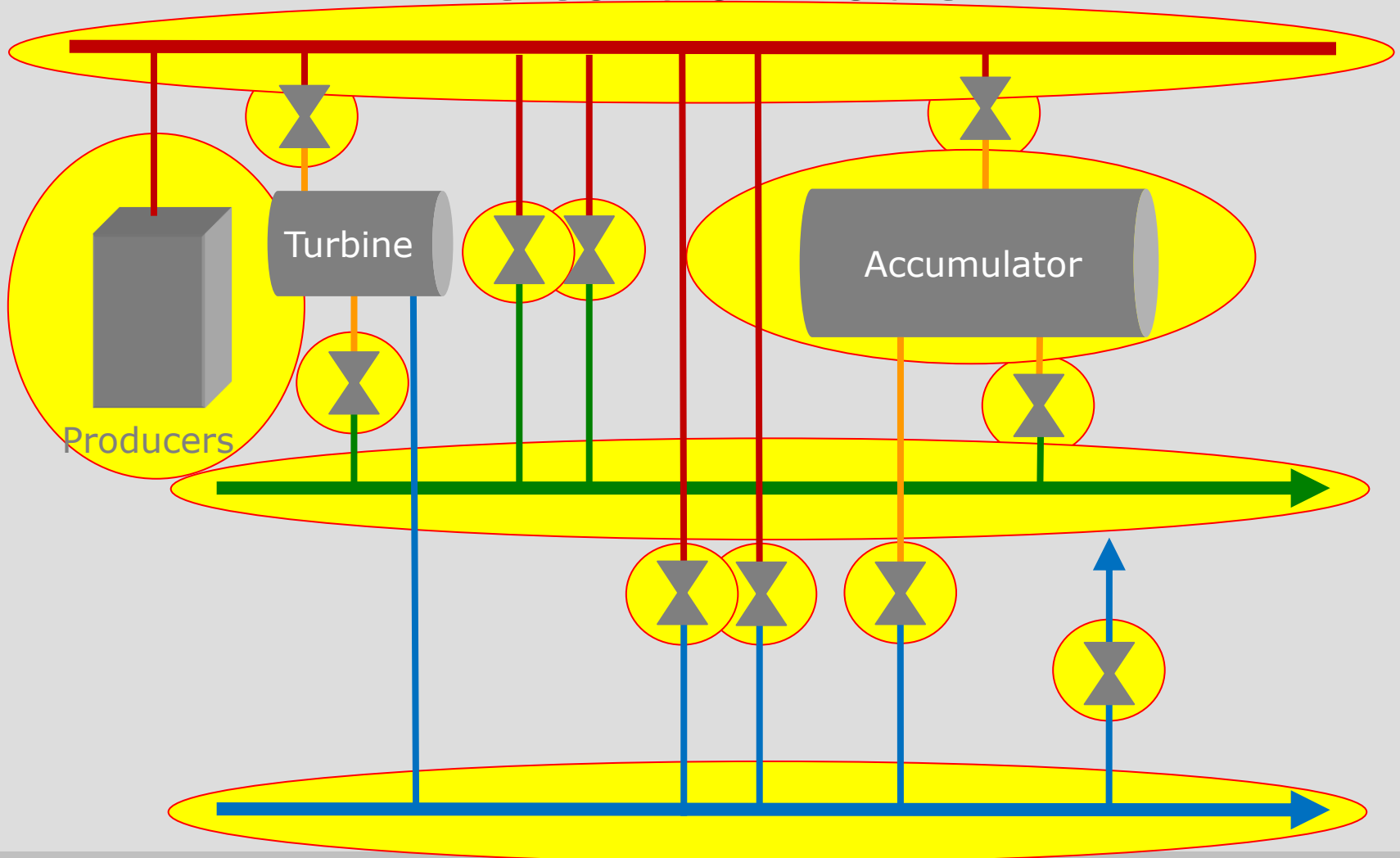



The Question:

What Makes an APC Installation Successful?



Control systems

- ▶ ABB 800xA
- ▶ ABB Freelance
- ▶ Honeywell TDC 3000
- ▶ Siemens PCS
- ▶ Siemens T300

- ▶ Basic Math
- ▶ PID Control
 - ▶ Man/Auto
 - ▶ Anti-Windup
 - ▶ Feed-Forward
 - ▶ Variable Output Limits

**Does it Depend
on the Control
System?**

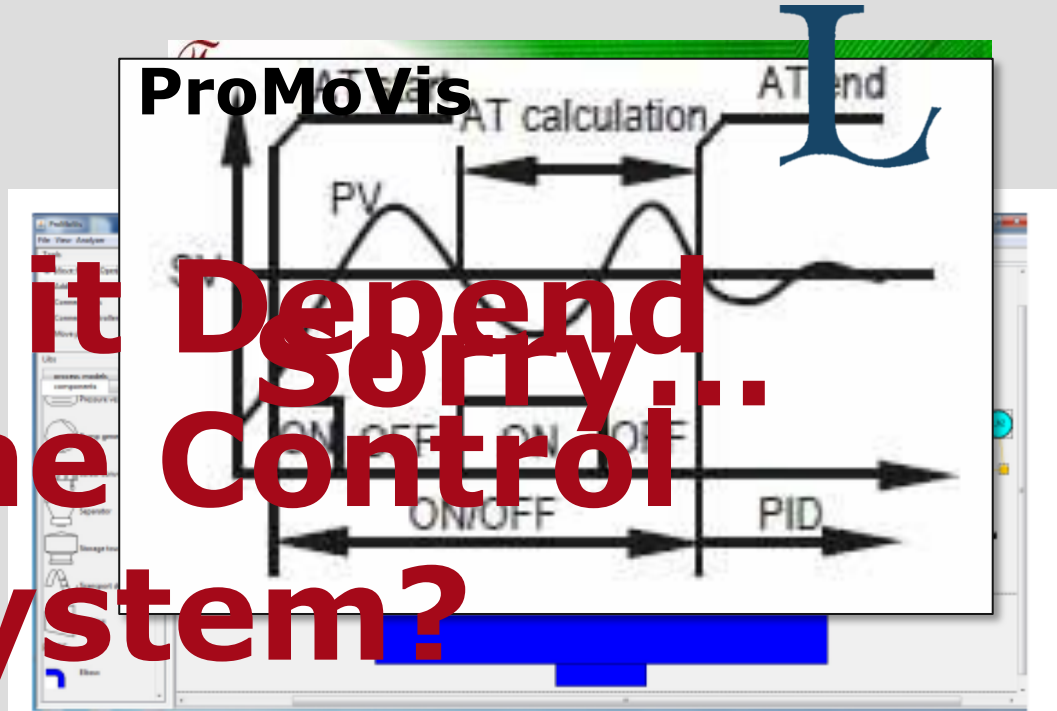
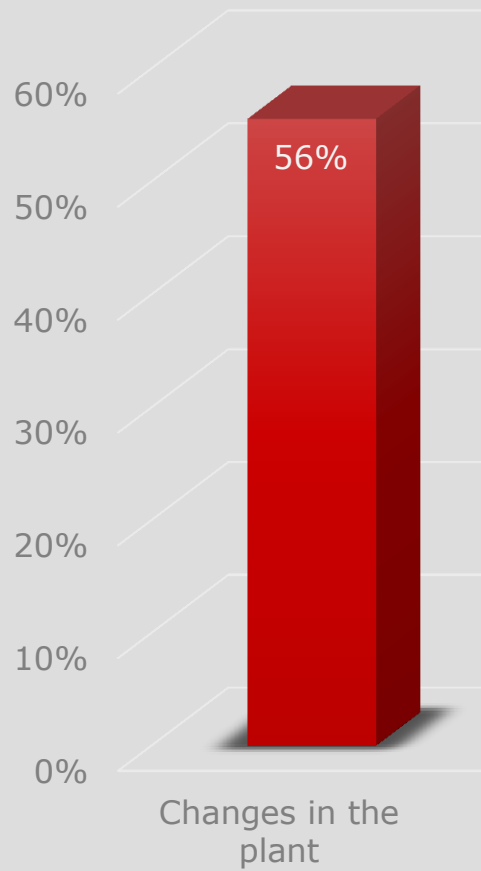

Fig. 1. Screenshot of ProMoVis with an implementation of the quadruple-tank process. The red edges represent process models and the yellow edges represent connections within the control system such as controllers, soft sensors or estimators.



Plants are Changing





Control structure

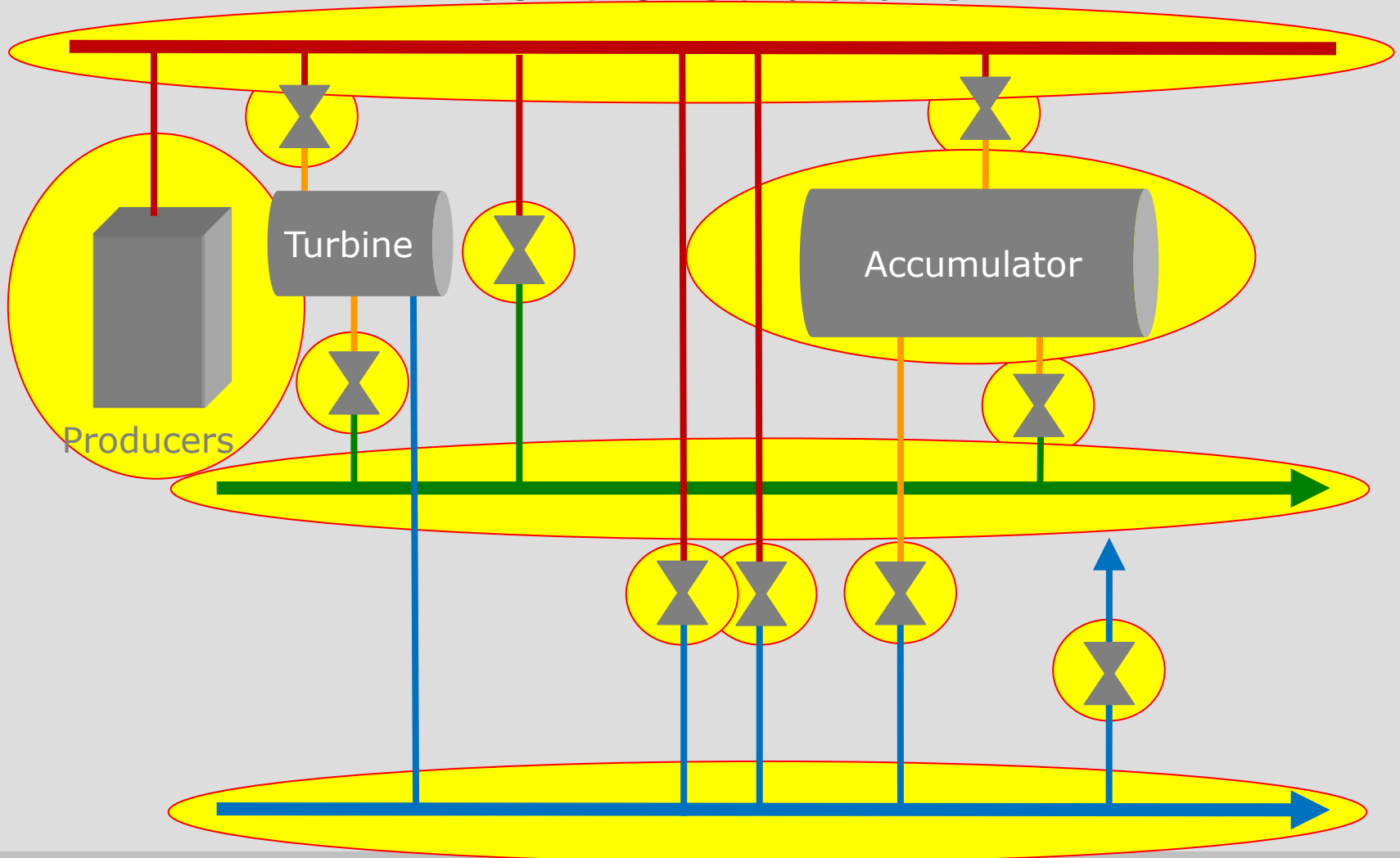



MPC

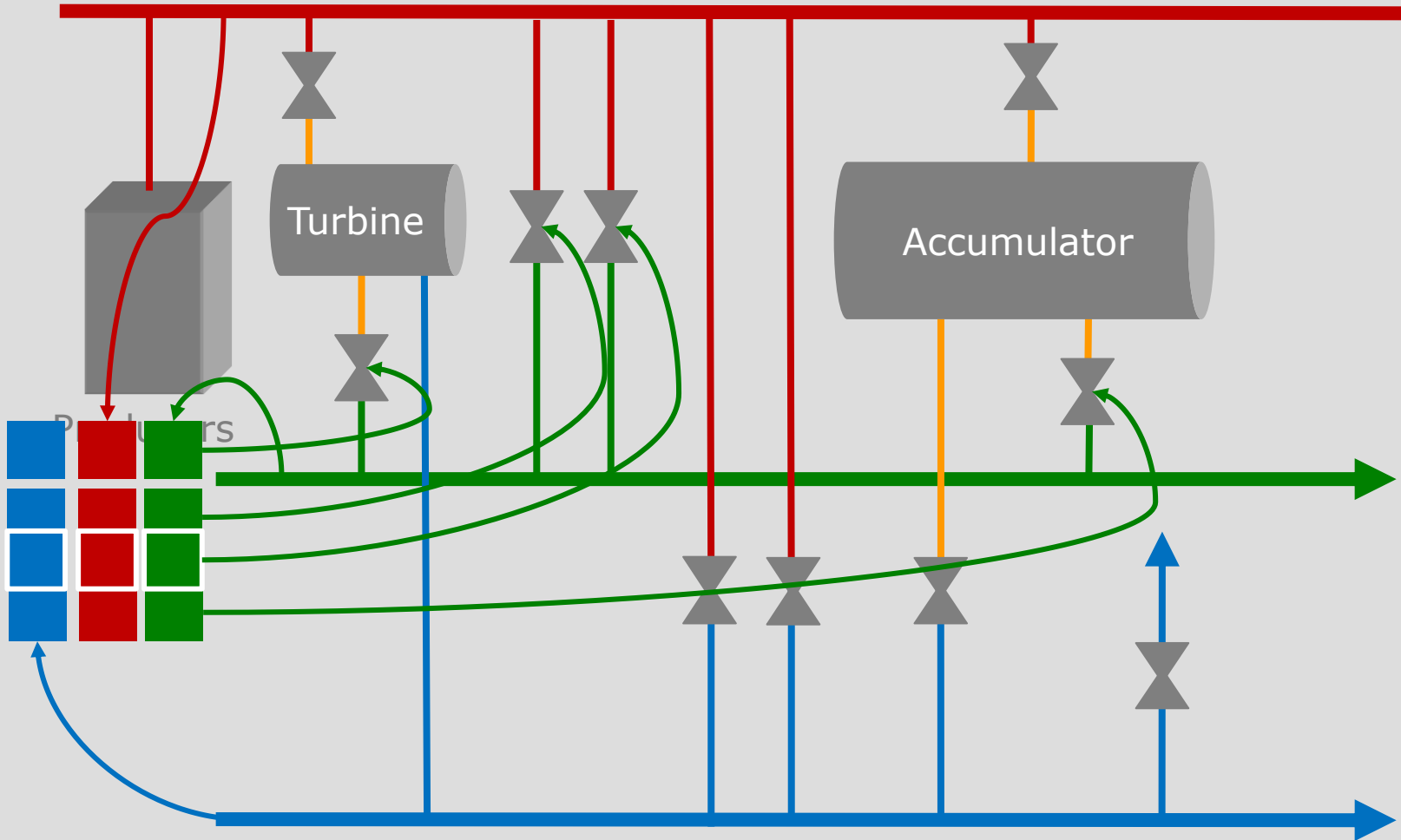



Modular PID approach

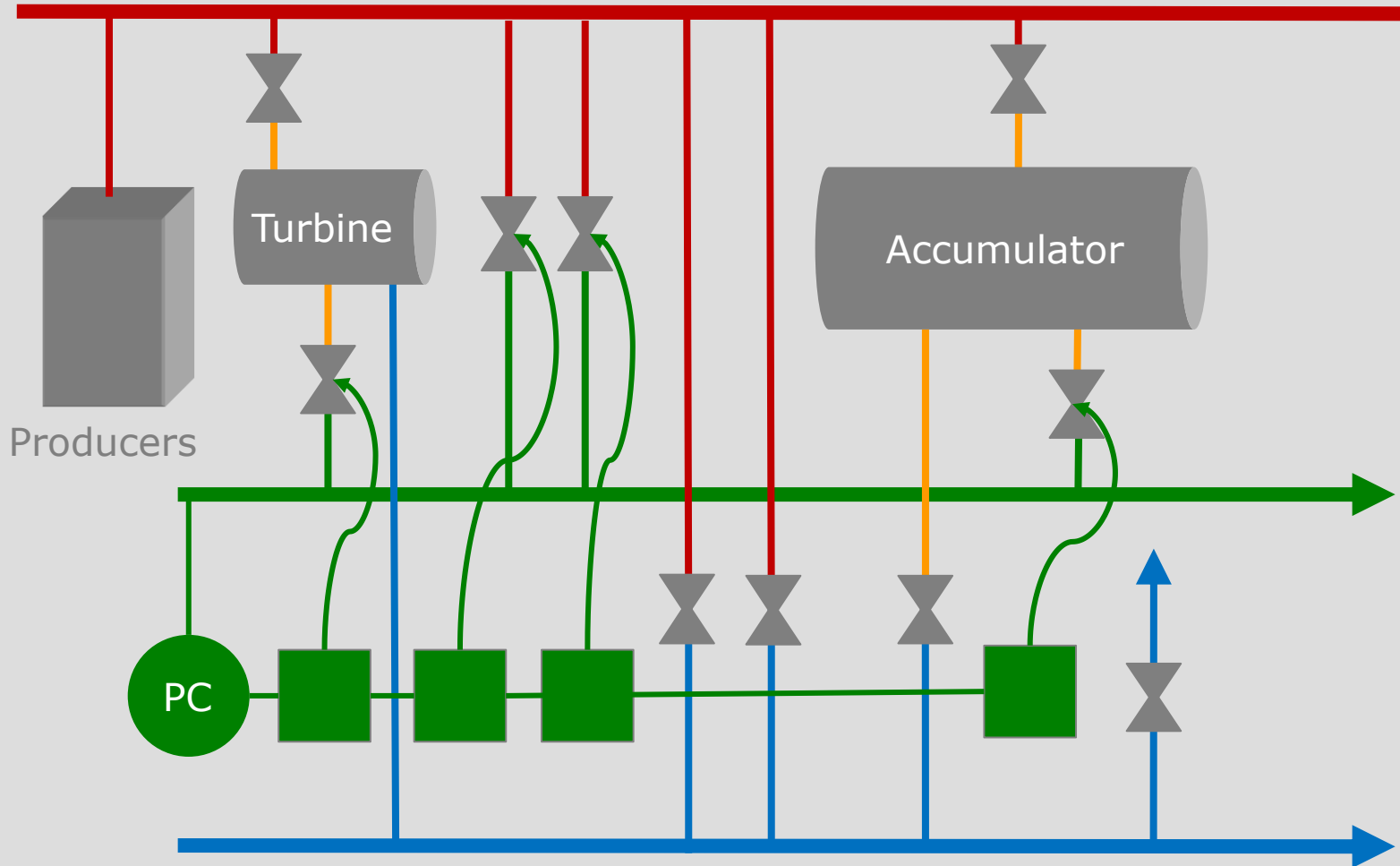



Acceptance from the Customers

- ▶ Education before start-up
- ▶ Well tested before start-up
- ▶ Can handle all situations
(or at least most of them)
- ▶ Freedom to the operators
- ▶ Refresher training after start-up





Maintenance

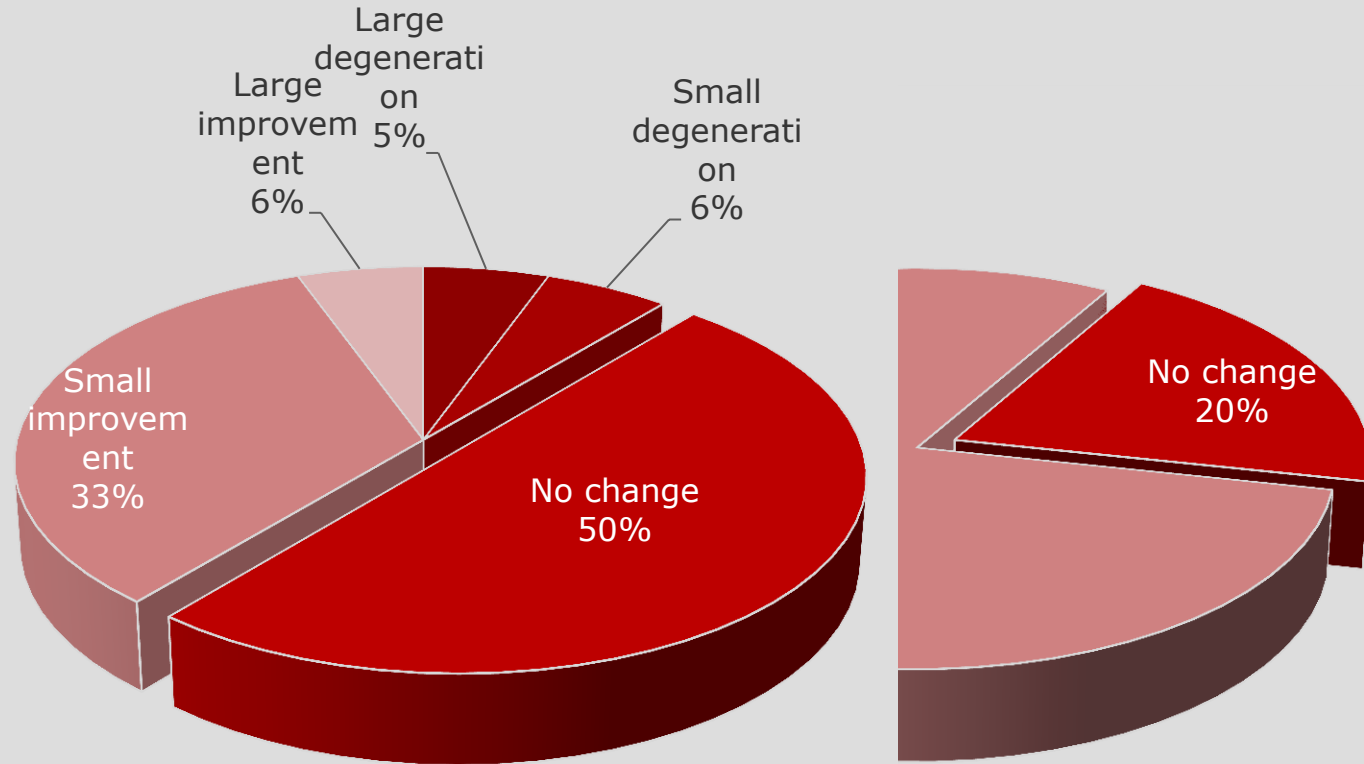

All Systems

Only Changed Systems
Mill Changes



The Question:

What Makes an APC Installation Successful?



The Answer:

- ▶ **Acceptance from the customer**
- ▶ **Ability to Handle Changes**
- ▶ **Maintenance**